



101 Physical Standards

Overview

- 1.0 Physical Standards for Letters
- 2.0 Physical Standards for Flats
- 3.0 Physical Standards for Parcels
- 4.0 Additional Physical Standards for Express Mail
- 5.0 Additional Physical Standards for Priority Mail
- 6.0 Additional Physical Standards for First-Class Mail
- 7.0 Additional Physical Standards for Parcel Post
- 8.0 Additional Physical Standards for Media Mail
- 9.0 Additional Physical Standards for Library Mail

1.0 Physical Standards for Letters

1.1 Dimensional Standards for Letters

Letter-size mail is:

- a. Not less than 5 inches long, 3-1/2 inches high, and 0.007-inch thick.
- b. Not more than 11-1/2 inches long, or more than 6-1/8 inches high, or more than 1/4-inch thick.
- c. Not more than 3.5 ounces (First-Class Mail letter-size pieces over 3.5 ounces pay flat-size prices).
- d. Rectangular, with four square corners and parallel opposite sides. Letter-size, card-type mailpieces made of cardstock may have finished corners that do not exceed a radius of 0.125 inch (1/8 inch). See [Exhibit 1.1d](#).

Exhibit 1.1d Maximum Corner Radius for Letter-Size, Card-Type Mailpieces

Corner Radius Maximum 1/8"

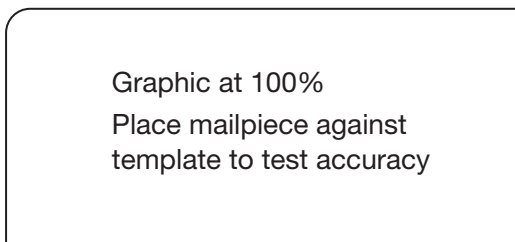



101.1.2

1.2 Nonmachinable Criteria

A letter-size piece is nonmachinable (see [6.4](#)) if it has one or more of the following characteristics (see [601.1.4](#) to determine the length, height, top, and bottom of a mailpiece):

- a. Has an aspect ratio (length divided by height) of less than 1.3 or more than 2.5.
- b. Is polybagged, polywrapped, enclosed in any plastic material, or has an exterior surface made of a material that is not paper. Windows in envelopes made of paper do not make mailpieces nonmachinable. Attachments allowable under applicable eligibility standards do not make mailpieces nonmachinable.
- c. Has clasps, strings, buttons, or similar closure devices.
- d. Contains items such as pens, pencils, keys, or coins that cause the thickness of the mailpiece to be uneven; or loose keys or coins or similar objects not affixed to the contents within the mailpiece. Loose items may cause a letter to be nonmailable when mailed in paper envelopes; (see [601.2.3, Odd-Shaped Items in Paper Envelopes](#)).
- e. Is too rigid (does not bend easily when subjected to a transport belt tension of 40 pounds around an 11-inch diameter turn).
- f. For pieces more than 4-1/4 inches high or 6 inches long, the thickness is less than 0.009 inch.
- g. Has a delivery address parallel to the shorter dimension of the mailpiece.
- h. Is a self-mailer that is not prepared according to [201.3.14](#).
- i. Is a booklet that is not prepared according to [201.3.15](#).

2.0 Physical Standards for Flats

2.1 General Definition of Flat-Size Mail

Flat-size mail is:

- a. More than 11-1/2 inches long, or more than 6-1/8 inches high, or more than 1/4 inch thick.
- b. Not more than 15 inches long, or more than 12 inches high, or more than 3/4 inch thick.
- c. Flexible (see [2.3](#)).
- d. Rectangular with four square corners or with finished corners that do not exceed a radius of 0.125 inch (1/8 inch). See [Exhibit 2.1d](#).

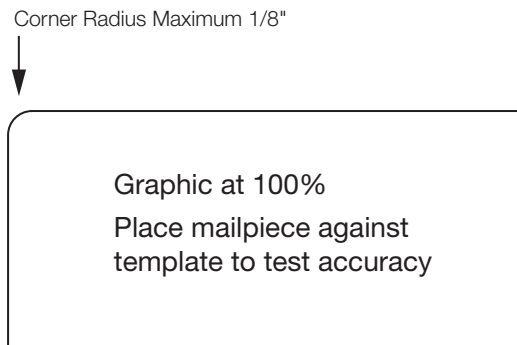
**Exhibit 2.1d Maximum Corner Radius for Flat-Size Mailpieces**

- e. Uniformly thick (see 2.4).
- f. Unwrapped, sleeved, wrapped, or enveloped.

2.2 Length and Height of Flats

The length of a flat-size mailpiece is the longest dimension. The height is the dimension perpendicular to the length.

2.3 Minimum Flexibility Criteria for Flat-Size Pieces

Flat-size pieces must be flexible. Boxes—with or without hinges, gaps, or breaks that allow the piece to bend—are not flats. Tight envelopes or wrappers that are filled with one or more boxes are not flats. At the customer's option, a customer may perform the following test on their own mailpieces. When a postal employee observes a customer demonstrating that a flat-size piece is flexible according to these standards, the employee does not need to perform the test. Test flats as follows:

- a. All flats (see Exhibit 2.3a):
 1. Place the piece with the length parallel to the edge of a flat surface and extend the piece halfway off the surface.
 2. Press down on the piece at a point 1 inch from the outer edge, in the center of the piece's length, exerting steady pressure.
 3. The piece is *not* flexible if it cannot bend at least 1 inch vertically without being damaged.
 4. The piece *is* flexible if it can bend at least 1 inch vertically without being damaged and it does not contain a rigid insert. No further testing is necessary.
 5. Test the piece according to 2.3b or 2.3c below if it can bend at least 1 inch vertically without being damaged and it contains a rigid insert.



Exhibit 2.3a Flexibility Test—All Flats

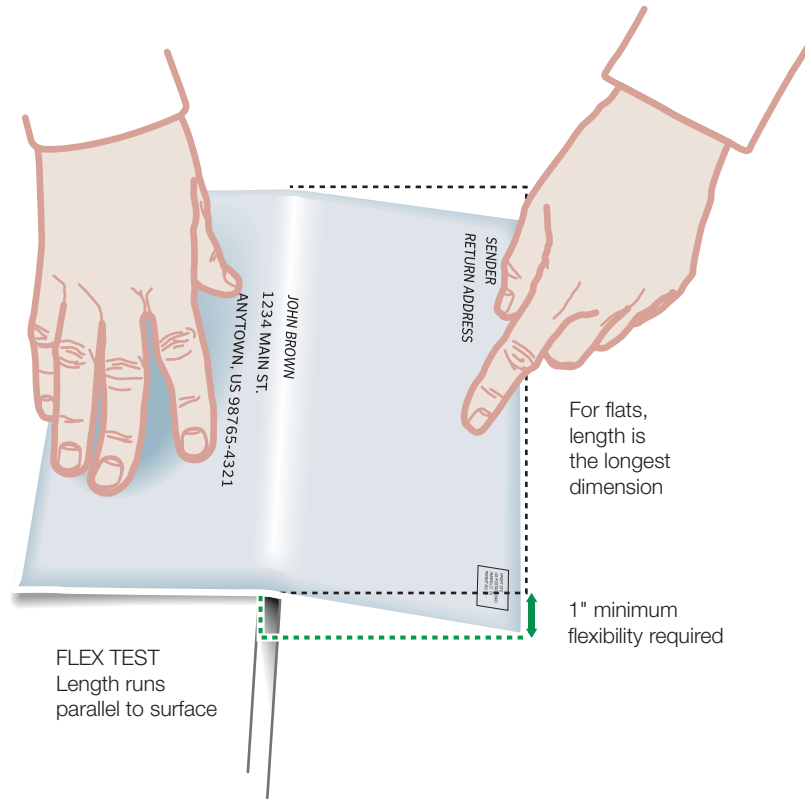

- b. Flats 10 inches or longer that pass the test in [2.3a](#) and contain a rigid insert (see [Exhibit 2.3b](#)):
 1. Place the piece with the length perpendicular to the edge of a flat surface and extend the piece 5 inches off the surface.
 2. Press down on the piece at a point 1 inch from the outer edge, in the center of the piece's width, exerting steady pressure.
 3. Turn the piece around and repeat steps 1 and 2. The piece is flexible if both ends can bend at least 2 inches vertically without being damaged.



Exhibit 2.3b Flexibility Test—Flats 10 Inches or Longer

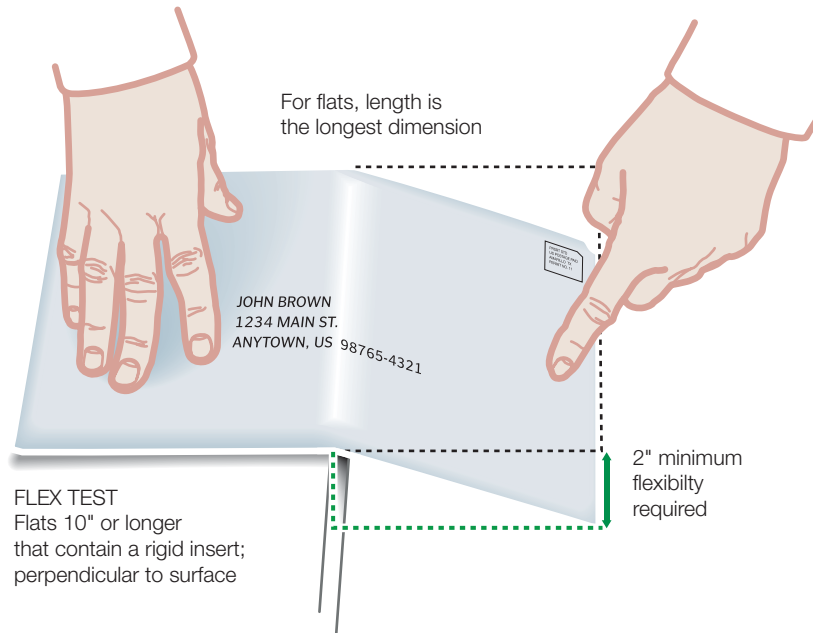

- c. Flats less than 10 inches long that pass the test in [2.3a](#) and contain a rigid insert (see [Exhibit 2.3c](#)):
 1. Place the piece with the length perpendicular to the edge of a flat surface and extend the piece one-half of its length off the surface.
 2. Press down on the piece at a point 1 inch from the outer edge, in the center of the piece's width, exerting steady pressure.
 3. Turn the piece around and repeat steps 1 and 2. The piece is flexible if both ends can bend at least 1 inch vertically without being damaged.



Exhibit 2.3c Flexibility Test—Flats Less Than 10 Inches Long

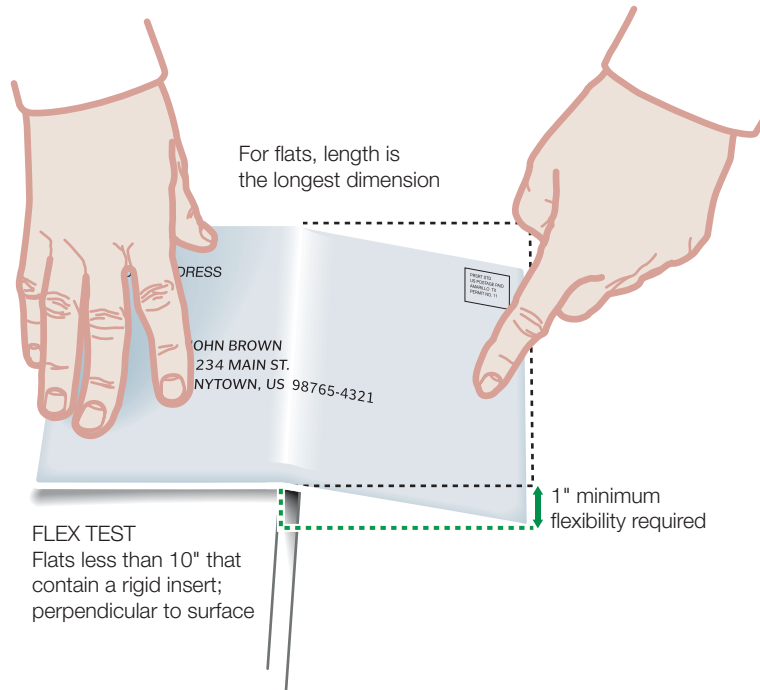

2.4 Uniform Thickness

Flat-size mailpieces must be uniformly thick so that any bumps, protrusions, or other irregularities do not cause more than 1/4-inch variance in thickness. When determining variance in thickness, exclude the outside edges of a mailpiece (1 inch from each edge) when the contents do not extend into those edges. Also, exclude the selvage of any polywrap covering (see [301.1.5](#)) from this determination. Mailers must secure nonpaper contents to prevent shifting of more than 2 inches within the mailpiece if shifting would cause the piece to be nonuniform in thickness or would result in the contents bursting out of the mailpiece (see [601.2.3](#)).

2.5 Flat-Size Pieces Not Eligible for Flat-Size Pricing

Mailpieces that do not meet the standards in [2.1](#) through [2.4](#) are not eligible for flat-size pricing and must pay applicable parcel prices.

3.0 Physical Standards for Parcels

3.1 Maximum Weight and Size

No mailpiece may weigh more than 70 pounds. Lower weight limits apply to First-Class Mail, Standard Mail, and Bound Printed Matter. Pieces may not measure more than 108 inches in length and girth combined, except Parcel Post, which may not measure more than 130 inches in length and girth combined. For parcels, length is the distance of the longest dimension and girth is the distance around the thickest part. Lower size or weight standards apply to mail addressed to some APOs and FPOs subject to [703.2.0](#) and [703.4.0](#) and for Department of State mail, subject to [703.3.0](#).

**3.2 Two or More Packages**

Two or more packages may be mailed as a single parcel, if they are about the same size or shape, if they are securely wrapped or fastened together, and if they do not together exceed the weight or size limits.

3.3 Machinable Parcels

A machinable parcel is any piece that is (see [Exhibit 3.3](#)):

- a. Not less than 6 inches long, 3 inches high, 1/4 inch thick, and 6 ounces in weight. (A mailpiece exactly 1/4 inch thick is subject to the 3 1/2-inch height minimum under [601.1.2](#).)
- b. Not more than 34 inches long, or 17 inches high, or 17 inches thick, or 35 pounds in weight. For books, or other printed matter, the maximum weight is 25 pounds.

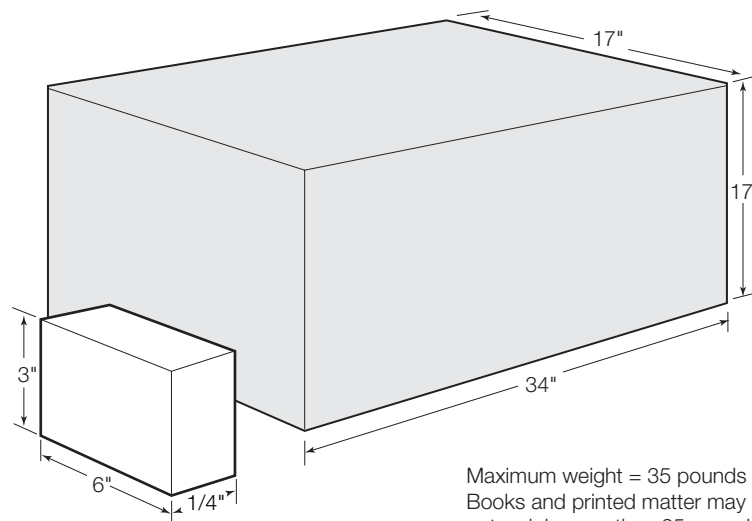
Exhibit 3.3 Machinable Parcel Dimensions

Maximum weight = 35 pounds
Books and printed matter may not weigh more than 25 pounds.

Minimum weight = 6 oz.
(for details, see machinable parcel criteria in [401.1.5.1](#))



101.3.4

3.4 Soft Goods and Enveloped Printed Matter

Soft goods wrapped in paper or plastic bags and enveloped printed matter are machinable only if all packaging standards in [601.2.0](#) are met.

3.5 Irregular Parcels

An irregular parcel is a parcel not meeting the dimensional criteria in [3.3, Machinable Parcels](#). This processing category also includes parcels that cannot be processed by Bulk Mail Center parcel sorters, including rolls and tubes up to 26 inches long; merchandise samples that are not individually addressed and are not letter-size or flat-size; unwrapped, paper-wrapped, or sleeve-wrapped articles that are not letter-size or flat-size; and articles enclosed in envelopes that are not letter-size, flat-size, or machinable parcels.

3.6 Outside Parcel

An outside parcel is a parcel that exceeds any of the maximum dimensions for a machinable parcel. This processing category also includes high-density parcels (other than books and printed matter) weighing more than 15 pounds and exerting more than 60 pounds per square foot (0.4167 pound per square inch) pressure on their smallest side; cartons containing more than 24 ounces of liquid in one or more glass containers; cartons containing 1 gallon or more of liquid in metal or plastic containers; cans, paints; rolls and tubes longer than 26 inches; metal-band strapped boxes, metal boxes, and wood boxes; articles not mailed in boxes or other containers; harmful matter; hazardous materials except ORM-D materials; and containers with all dimensions exceeding the minimum dimensions for a machinable (regular) parcel, if their coefficient of friction or ability to slide on a smooth, hard surface is not similar to that of a domestic-class fiberboard box of the same approximate size and weight.

4.0 Additional Physical Standards for Express Mail

4.1 Physical Standards of Mailpieces

Each piece of Express Mail may not weigh more than 70 pounds. The combined length and girth of a piece (the length of its longest side plus the distance around its thickest part) may not exceed 108 inches. Lower size or weight standards apply to Express Mail addressed to certain APOs and FPOs.

4.2 Outside Parcels

Express Mail items not required to be presented in a pouch (outside parcels) must be large enough to hold the required mailing labels and indicia without bending or folding on a single optical plane.

4.3 Two or More Packages

With the exception of USPS-produced Express Mail flat-rate envelopes, two or more packages may be mailed as a single parcel if they are about the same size or shape, are securely wrapped or fastened together, and do not exceed the weight or size limits.



5.0 Additional Physical Standards for Priority Mail

5.1 Physical Standards of Mailpieces

The maximum weight is 70 pounds. The combined length and girth of a piece (the length of its longest side plus the distance around its thickest part) may not exceed 108 inches. Lower size and weight standards apply for some APO and FPO mail subject to [703.2.0, Overseas Military Mail](#), and [703.4.0, Mail Sent by U.S. Armed Forces](#), and for Department of State mail subject to [703.3.0](#).

5.2 Two or More Packages

With the exception of USPS-produced Priority Mail flat-rate envelopes or boxes, two or more packages may be mailed as a single parcel if they are about the same size or shape, are securely wrapped or fastened together, and do not exceed the weight or size limits.

5.3 Balloon Price

Pieces addressed for delivery to zones 1-4 (including local) and weighing less than 20 pounds but measuring more than 84 inches in combined length and girth are charged the price for a 20-pound parcel for the zone to which it is addressed. See [123.1.3](#).

5.4 Dimensional Weight Price

Postage for parcels addressed for delivery to zones 5-8 and exceeding 1 cubic foot (1,728 cubic inches) is based on the actual weight or the dimensional weight (see [123.1.4](#)), whichever is greater.

6.0 Additional Physical Standards for First-Class Mail

6.1 Maximum Weight and Size

First-Class Mail cannot exceed 13 ounces. First-Class Mail weighing more than 13 ounces is Priority Mail ([123, Prices and Eligibility](#)). The combined length and girth of a piece (the length of its longest side plus the distance around its thickest part) may not exceed 108 inches. Lower size or weight standards apply to mail claimed at certain prices or addressed to some APOs and FPOs subject to [703.2.0](#) and [703.4.0](#) and for Department of State mail subject to [703.3.0](#).

6.2 Minimum Standards

Pieces are subject to the minimum standards in [601.1.2](#) and may be subject to other minimum dimensions, based on the standards for specific prices.

6.3 Cards Claimed at Card Prices

6.3.1 Card Price

A card may be a single or double (reply) stamped card or a single or double postcard. Stamped cards are available from USPS with postage imprinted on them. Postcards are commercially available or privately printed mailing cards. To be eligible for card pricing, a card and each half of a double card must meet the physical standards in [6.3](#) and the applicable eligibility and preparation standards for the price



claimed. Ineligible cards are subject to letter-size pricing. Cards may be prepared and mailed at the First-Class Mail single-piece card, Presorted card, or automation card prices.

6.3.2 Postcard Dimensions

Each card (each stamped card or postcard or each half of a double stamped card or postcard) claimed at card pricing must be:

- a. Rectangular.
- b. Not less than 3-1/2 inches high, 5 inches long, and 0.007 inch thick.
- c. Not more than 4-1/4 inches high, or more than 6 inches long, or greater than 0.016 inch thick.

6.3.3 Other Cards

A card that does not meet the applicable standards in [6.3](#) must not bear the words “Postcard” or “Double Postcard.”

6.3.4 Paper or Card Stock

A card must be of uniform thickness and made of unfolded and uncreased paper or cardstock of approximately the quality and weight of a stamped card (i.e., a card available from the USPS). A card must be formed either of one piece of paper or cardstock or of two pieces of paper permanently and uniformly bonded together. The stock used for a card may be of any color or surface that permits the legible printing of the address, postmark, and any required markings.

6.3.5 Acceptable Attachments

A card may bear an attachment that is:

- a. A paper label, such as a wafer seal or decal affixed with permanent adhesive to the back side of the card, or within the message area on the address side (see [Exhibit 202.2.1](#)), or to the left of the address block.
- b. A label affixed with permanent adhesive for showing the delivery or return address.
- c. A small reusable seal or decal prepared with pressure-sensitive and nonremovable adhesive that is intended to be removed from the first half of a double card and applied to the reply half.

6.3.6 Unacceptable Attachment

A card may not bear an attachment that is:

- a. Other than paper.
- b. Not totally adhered to the card surface.
- c. An encumbrance to postal processing.

6.3.7 Tearing Guides

A card may have perforations or tearing guides if they do not eliminate or interfere with any address element, postage, marking, or endorsement and do not impair the physical integrity of the card.



6.3.8 Address Side of Cards

The address side of a card is the side bearing the delivery address and postage. The address side may be formatted to contain a message area. Cards that do not contain a message area on the address side are subject to the applicable standards for the price claimed. For the purposes of 6.3, miscellaneous graphics or printing, such as symbols, logos, or characters, that appear on the address side of cards not containing a message area are generally acceptable provided the items are not intended to convey a message.

6.3.9 Special Rules for Single-Piece Cards

Cards claimed at the single-piece price that have the format characteristics in 201.1.2.6a.3. or 201.1.2.6b.3. and are part of a mailing of 200 or more identical pieces must:

- a. Have addresses that include the correct ZIP Code or ZIP+4 code.
- b. Have postage paid with permit imprints, meter stamps, or precanceled stamps.
- c. Be prepared under 235.5.2, *Machinable Preparation*.

6.3.10 Double Cards

A double card (a double stamped card or double postcard) consists of two attached cards, one of which is designed to be detached by the recipient and returned by mail as a single card. Double cards are subject to these standards:

- a. The reply half of a double card must be used for reply only and may not be used to convey a message to the original addressee or to send statements of account. The reply half may be formatted for response purposes (e.g., contain blocks for completion by the addressee).
- b. A double card must be folded before mailing and prepared so that the address on the reply half is on the inside when the double card is originally mailed. The address side of the reply half may be prepared as Business Reply Mail, Courtesy Reply Mail, meter reply mail, or as a merchandise return service label.
- c. Plain stickers, seals, or a single wire stitch (staple) may be used to fasten the open edge at the top or bottom once the card is folded if affixed so that the inner surfaces of the cards can be readily examined. Fasteners must be affixed according to the applicable preparation requirements for the price claimed. Any sealing on the left and right sides of the cards, no matter the sealing process used, is not permitted.
- d. The first half of a double card must be detached when the reply half is mailed for return.

6.3.11 Enclosures

Enclosures in double postcards are prohibited at card prices.

6.4 Nonmachinable Pieces

6.4.1 Nonmachinable Letters

Letter-size pieces (except card-size pieces) that meet one or more of the nonmachinable characteristics in 1.2 are subject to the nonmachinable surcharge (see 133.1.10).



101.6.4.2

6.4.2 Nonmachinable Flats

Flat-size pieces that do not meet the standards in [2.0](#) are subject to the applicable postage for a parcel-size piece, based on weight.

6.5 Parcels

The address side of the parcel must be large enough to contain all delivery and return address, endorsement, postage, and label elements. First-Class Mail parcels are eligible for Delivery Confirmation and Signature Confirmation services. A First-Class Mail parcel is:

- a. A mailpiece that exceeds any one of the maximum dimensions for a flat (large envelope). See [2.1](#).
- b. A flat-size mailpiece, regardless of thickness, that is rigid or nonrectangular.
- c. A flat-size mailpiece that is not uniformly thick (has bumps, protrusions, or other irregularities that cause the thickness to vary more than 1/4 inch).

6.6 Two or More Packages

Two or more packages may be mailed as a single parcel, if they are about the same size or shape or if they are parts of one article, if they are securely wrapped or fastened together, and if they do not together exceed the weight or size limits.

7.0 Additional Physical Standards for Parcel Post

7.1 Dimension and Weight Standards

These standards apply to Parcel Post:

- a. No piece may weigh more than 70 pounds.
- b. Parcel Post pieces measuring over 108 inches in combined length and girth, but not more than 130 inches in combined length and girth, are mailable at the applicable oversized price.
- c. Parcel Post pieces measuring over 84 inches in combined length and girth, but not more than 108 inches in combined length and girth, and weighing less than 20 pounds are mailable at the price equal to that of a 20-pound parcel for the zone to which the parcel is addressed (balloon price).
- d. Two or more packages may be mailed as a single parcel, if they are about the same size or shape, if they are securely wrapped or fastened together, and if they do not together exceed the weight or size limits.
- e. Lower size or weight standards apply to mail addressed to some APOs and FPOs subject to [703.2.0](#) and [703.4.0](#) and for Department of State mail, subject to [703.3.0](#).

8.0 Additional Physical Standards for Media Mail

8.1 Dimension and Weight Standards

These standards apply to Media Mail:

- a. No piece may weigh more than 70 pounds.



- b. The combined length and girth of a piece (the length of its longest side plus the distance around its thickest part) may not exceed 108 inches.
- c. Two or more packages may be mailed as a single parcel, if they are about the same size or shape, if they are securely wrapped or fastened together, and if they do not together exceed the weight or size limits.
- d. Lower size or weight standards apply to mail addressed to certain APOs and FPOs, subject to [703.2.0](#) and [703.4.0](#) and for Department of State mail, subject to [703.3.0](#).

9.0 Additional Physical Standards for Library Mail

9.1 Dimension and Weight Standards

These standards apply to Library Mail:

- a. No piece may weigh more than 70 pounds.
- b. The combined length and girth of a piece (the length of its longest side plus the distance around its thickest part) may not exceed 108 inches.
- c. Two or more packages may be mailed as a single parcel, if they are about the same size or shape, if they are securely wrapped or fastened together, and if they do not together exceed the weight or size limits.
- d. Lower size or weight standards apply to mail addressed to certain APOs and FPOs, subject to [703.2.0](#) and [703.4.0](#) and for Department of State mail, subject to [703.3.0](#).

